

APPLICAZIONI

Gruppi di pressurizzazione a funzionamento automatico realizzati con elettropompe jet autoadescanti.

Molto affidabili e silenziosi sono particolarmente adatti per aumentare la pressione disponibile da una rete di distribuzione, per l'approvvigionamento d'acqua con aspirazione da pozzi e per impianti idrici domestici.

APPLICATION

Automatic high pressure groups coupled with selfpriming jet pumps.

They are very silent and reliable and particularly suitable to increase pressure from a water system, to supply water from wells and in domestic high pressure groups.

LIMITI D'IMPIEGO

- Temperatura liquido fino a 35°C
- Temperatura ambiente fino a 40°C
- Altezza d'aspirazione manometrica fino a 8 mt.
- Pressostato pre-tarato 1,6÷3,2 bar
- Servizio continuo

MOTORE

- Motore elettrico ad induzione a 2 poli ($n = 2850 \text{ min}^{-1}$)
- Isolamento Classe F
- Protezione IP 44

COMPONENTI

- Serbatoio a membrana
- Tubo flessibile raccordato
- Pressostato con cavi pre-tarato
- Manometro
- Raccordo ottone

OPERATING CONDITIONS

- Liquid temperature up to 35°C
- Ambient temperature up to 40°C
- Total suction lift up to 8 mt.
- Adjusted switch on/off pressure 1,6÷3,2 bar
- Continuous duty

MOTOR

- Two-Pole induction motor ($n = 2850 \text{ min}^{-1}$)
- Insulation Class F
- Protection IP 44

COMPONENTS

- Membrane tank
- Flexible hose with connection
- Pre-set pressure switch with cable
- Pressure gauge
- Brass connection

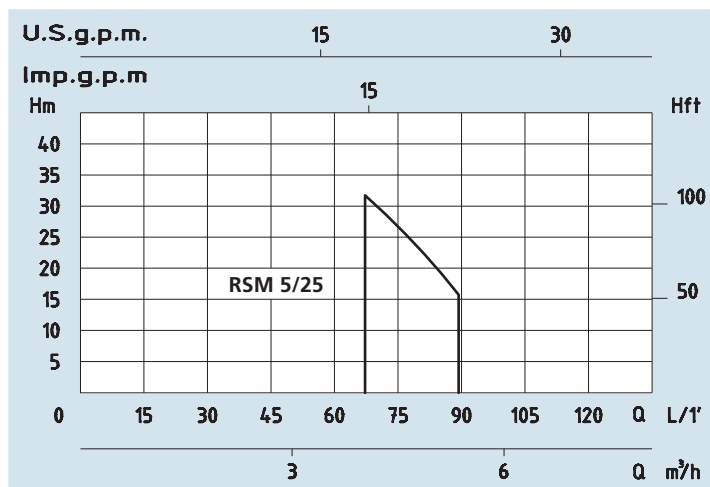
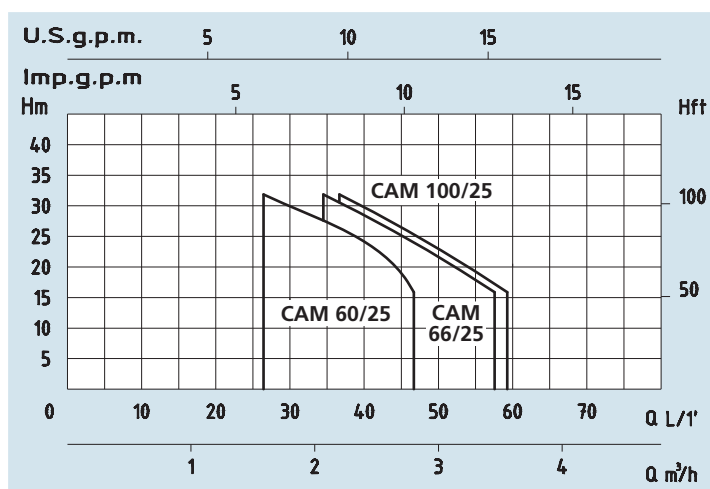

DATI TECNICI - TECHNICAL DATA

TIPO - TYPE	POTENZA NOMINALE NOMINAL POWER P2	POTENZA ASSORBITA INPUT POWER P1	AMPERE	Pressostato pre-tarato Adjusted switch on/off pressure	Q = PORTATA - CAPACITY															
					m³/h	0,6	0,9	1,2	1,5	1,8	2,1	2,4	2,7	3	3,6					
Monofase Single-phase	HP	kW	kW	1 x 230V	Bar	Prevalenza manometrica totale in m.C.A. - Total head in meters w.c.														
230V-50Hz																				
CAM 60/25	0,8	0,6	0,8	3,5	1,6 ÷ 3,2		42	38	36	33	30	27	26	23	20					
CAM 66/25	1	0,7	1	4,9	1,6 ÷ 3,2		46	43	40	37	35	33	30	29	26					
CAM 100/25	1	0,75	1,1	5	1,6 ÷ 3,2		45	43	40	38	35	33	30	29	26	22				
RSM 5/25	1,5	1,1	1,4	6,2	1,6 ÷ 3,2		62	61	60	58	55	54	52	50	45	40				



CAM 60-66-100

RSM 5

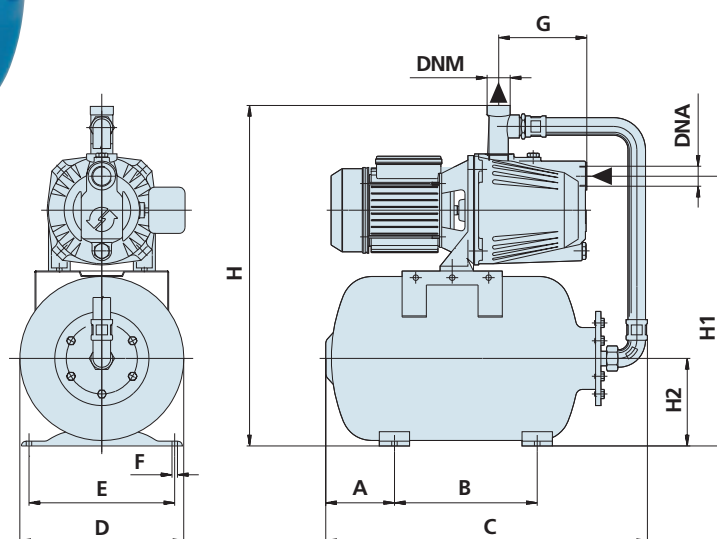

DIMENSIONI E PESI - DIMENSIONS AND WEIGHTS

TIPO - TYPE	DIMENSIONI mm - DIMENSIONS mm												DIMENSIONI DIMENSIONS mm 			Peso Weight
	A	B	C	D	E	F	G	H	H1	H2	DNA	DNM	P	L	H	Kg
Monofase Single-phase																
CAM 60/25	113	235	530	270	240	9	90	497	444	144	1"	1"	280	540	500	18
CAM 66/25	113	235	530	270	240	9	90	497	444	144	1"	1"	280	540	500	20
CAM 100/25	113	235	530	270	240	9	145	560	444	144	1"	1"	280	550	600	22
RSM 5/25	113	235	530	270	240	9	220	520	440	144	1"	1"	310	560	580	23