



SCHEMA TECNICA – TECHNICAL DATA

ST.POS.RGM.3.SP.

rev - 00

**Elettropompa Centrifuga Multigrante
Centrifugal Multi-Impeller Pump**

17/09/2012

Codice - Code : 102204010 **Bar code** 8006414066573

Descrizione - Description : EL.SPER.RGM 3

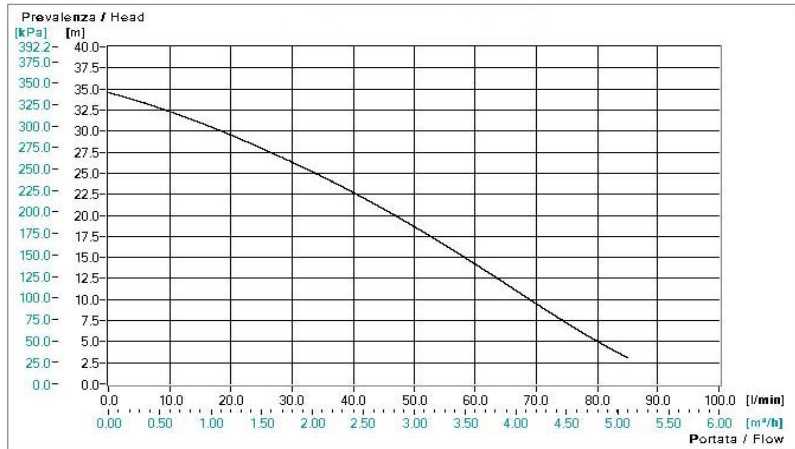

Elettropompe centrifughe multigranti sviluppano una notevole pressione e nel contempo un'elevata portata d'acqua con un basso consumo di energia. Per la grande silenziosità e le ottime caratteristiche idrauliche vengono impiegate in impianti domestici, piccola irrigazione a pioggia, lavaggio di veicoli e per l'assemblaggio di gruppi di pressione (autoclavi).

Centrifugal multi-impeller water pumps able to develop high pressure and a high water lift with a comparatively low power consumption. Thanks to their silent running and very good features, they are suitable in domestic fittings by tank pressure groups, for small sprinkler irrigations and car washing.

Motore - Motor	Motore elettrico ad induzione Induction motor	Pompa - Pump	Elettropompa Centrifuga Multigrante Centrifugal Multi-Impeller Pump
Poli/Giri motore Pole/Speed motor	2 Poli-Pole 2800 min ⁻¹	Diametro aspirazione - Diameter suction	1"
Fasi - Phase	Monofase - Single phase	Diametro mandata - Diameter discharge	1"
Servizio - Duty	Continuo - Continuous S1	Prevalenza - Delivery head max	30 5 m
Protezione - Protection	IP44	Portata - Capacity	20 80 l/min
Classe Isolamento - Insulation class	F	N° Giranti - Impellers N°	3
Tensione alimentazione Supply voltage	230 Volt 50 Hz	Materiali - Materials	
Corrente assorbita Current input	3,3 Ampere	Corpo pompa - Pump body	Ghisa - Cast Iron
Potenza nominale P2 Nominal power P2	550 Watt - 0,75 HP	Supporto - Support	Ghisa - Cast Iron
Condensatore - Capacitor	16 µF	Girante - Impeller	Noryl
		Diffusore - Diffuser	Noryl
		Albero motore Shaft with rotor	Acciaio inox Stainless Steel
		Tenuta meccanica Mechanical seal	Ceramica/Carbone Carbon/Ceramic

Limiti d'impiego - Operating conditions	Cavo - Cable	Dimensioni - Dimensions
Temperatura liquido fino a Liquid temperature up to		Peso netto - Net weight Kg
Temperatura Ambiente fino a Ambient temperature up to		

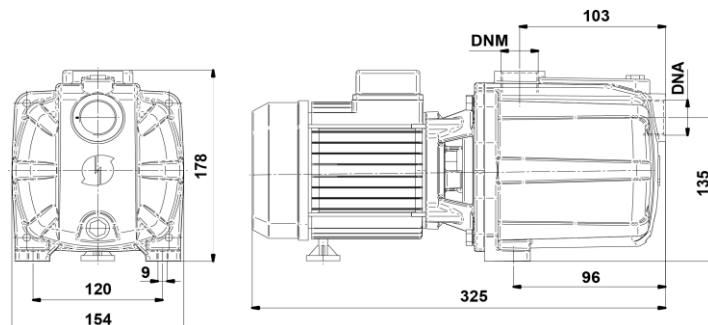

42024 CASTELNOVO SOTTO(Reggio Emilia) ITALY-Via S.Biagio, 59/A
Tel. 0522.487011 – Fax (Italy)+39.0522 487019 - Fax (World)+39.0522 683070
www.speroni.it - speroni @ speroni.it